



EXRAIL®

EXRAIL

STRUCTURE AND ADVANTAGES	··· X-2
BLOCK TYPES	····· X-3
ACCURACY	····· X-3
ACCURACY MEASUREMENT METHOD	··· X-4
PRELOAD	····· X-5
LOAD RATING AND RATED LIFE	··· X-5
RAIL LENGTH	····· X-6
MOUNTING	····· X-6
MOUNTING METHOD	····· X-8
DUST PREVENTION	····· X-13
GREASE FITTING	····· X-13
LUBRICATION	····· X-14
USE AND HANDLING PRECAUTIONS	··· X-15
DIMENSION TABLE	····· X-16~

ROLLER GUIDE EXRAIL®

The NB roller guide EXRAIL is the latest innovation of the linear motion bearing utilizing the rolling motion of needle rollers which achieve high rigidity, high motion accuracy, and high damping capability. Can be used for variety of applications such as precision machining equipment requiring high load and precision motion capability.

STRUCTURE AND ADVANTAGES

The NB roller guide EXRAIL consists of a rail with 4 rows of precisely machined raceway grooves and a block assembly. The block consisting of the main body, needle rollers, return caps and seals.

High Rigidity

Miniature needle rollers allows increase in the number of rollers and disperses the load onto each roller, reducing the load prevents elastic deformation and allows the rigidity to become more than 1.5 times higher compared to other competitors.

High Motion Accuracy

Since load is dispersed among multiple miniature needle rollers, it reduces the rolling element passage vibration(※) occurring during movement of linear guides to less than 1/2.

Corrosion Resistant Option

Corrosion resistant option is available by treating with low temperature black chrome. Please contact NB for details.

High Damping Capability

Dynamic friction becomes relatively larger since the number of rollers is increased, and time for convergence of oscillation is shortened. This allows vibration damping to be more than 1.5 times higher than that of conventional guide blocks.

Dust Prevention

As a standard feature, it is also equipped with under seal and inner seal to prevent foreign particles from entering the contact area of block, rail and rollers in addition to normal side seals to provide dust prevention. (refer to Figure X-1). Double seals and scrapers that improve dustproof performance are also available.

Maintenance Free Mechanism

Equipped with lubricated porous resin material as standard feature. Porous resin will provide gradual supply of lubrication oil which extends lubrication intervals, and contributing to reduce the maintenance workload and the cost (refer to Figure X-1).

Figure X-1 Structure of EXRAIL

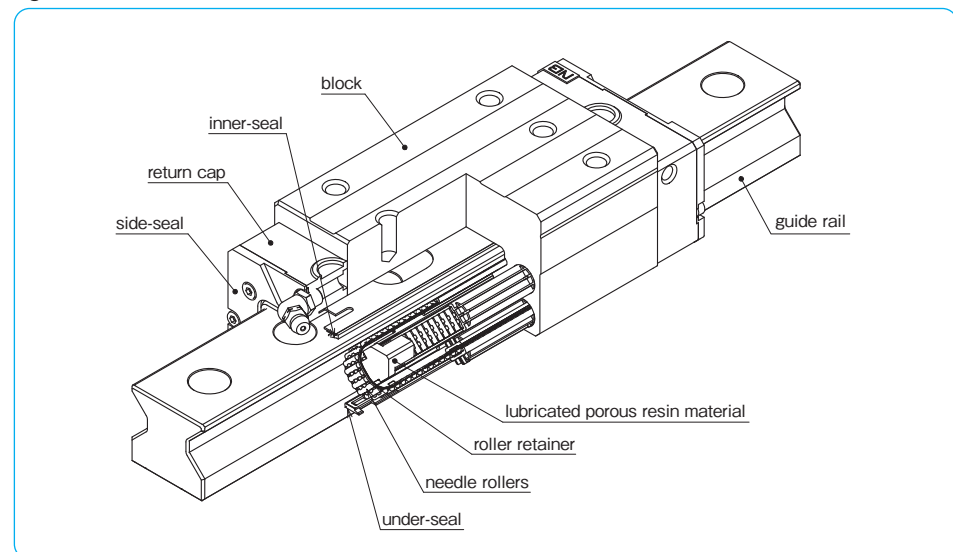

(※)the rolling element passage vibration: the vibration due to the periodic postural change due to the amount and position of the rolling elements supporting the load.

BLOCK TYPES

Two EXRAIL block types are available depending on the mounting methods.

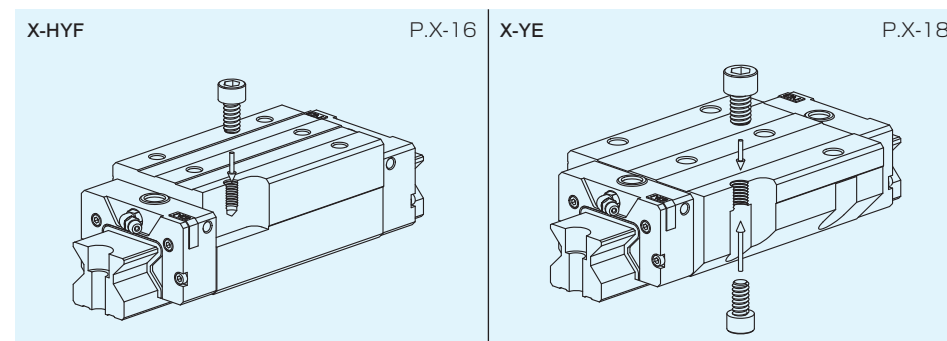

ACCURACY

The EXRAIL guides are available with only high grade (H) accuracy.

Table X-1 Accuracy

part number	X35	X45, 55
accuracy grade	high	
accuracy symbol	H	
allowable dimensional difference in height H	±0.04	±0.05
paired difference for height H	0.015	0.015
allowable dimensional difference in width W	±0.04	±0.05
paired difference for width W	0.015	0.02
running parallelism of surface C to surface A	refer to Figure X-2,3	
running parallelism of surface D to surface B		

unit: mm

Figure X-2 Motion Accuracy

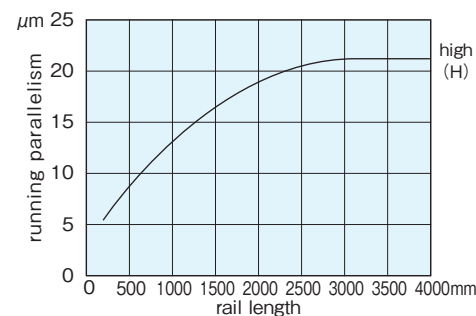
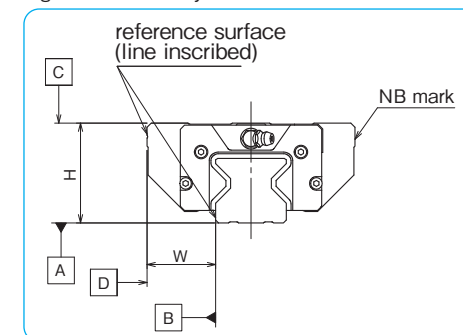

Figure X-3 Accuracy



ACCURACY MEASUREMENT METHOD

The accuracy of the EXRAIL guides is expressed in terms of the value at the center portion.

Dimensional Tolerance and Paired Difference

The accuracy of the EXRAIL guide is obtained by measuring the height H, and width W, as shown in Figure X-3 on P.X-3. The dimensional tolerance is measured for each of the blocks attached to the rail and is expressed in terms of the deviation from the basic dimension. The paired difference is obtained by measuring the blocks attached to the rail and is expressed in terms of the difference between the maximum and minimum values.

Motion Accuracy

The rail is first fixed to the reference base. The motion accuracy is obtained by measuring the difference in the indicator readings (running parallelism) when the block is moved along the entire span of the rail.
 Note: Gauge head is placed on the center of the block reference surface.

Figure X-4 Measurement Method for Motion Accuracy

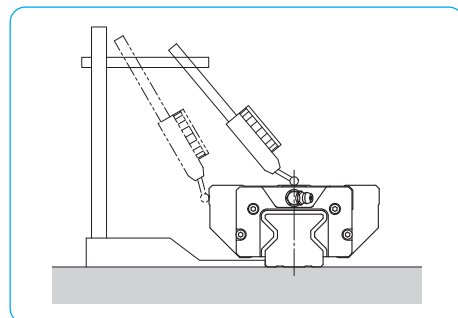

Notation for Number of Axes and Paired Difference

When more than one EXRAIL is used in parallel, the dimensional difference must be measured on more than one block on more than one rail. For measuring the paired difference for height H, please specify the number of axes (W2, W3) as the part number example shows. For measuring the paired difference for width W, please contact NB.

Note : When four EXRAILs are used as illustrated in Figure X-5, W4 should be specified in the part number. Please indicate the number of axes when ordering.

part number example
X35HYFB2-600H/W2

symbol for number of axes
 W2 : 2 parallel axes
 W3 : 3 parallel axes

Figure X-5 4 Parallel Axes

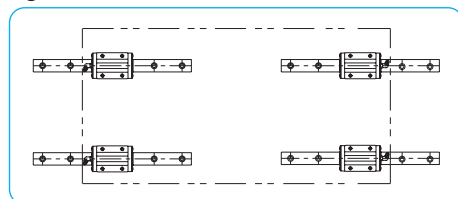

PRELOAD

The EXRAIL guides are available only with a standard preload.

Table X-2 Preload Level and Preload Symbol unit : μm

preload	standard
symbol	blank
X35	-2~0
X45	-2~0
X55	-3~-1

LOAD RATING AND RATED LIFE

Loading Direction and Load Rating

An EXRAIL guide experiences load and moment, as shown in Figure X-6. For each load and moment, the basic load ratings and allowable static moments are defined.

Figure X-6 Direction of Load

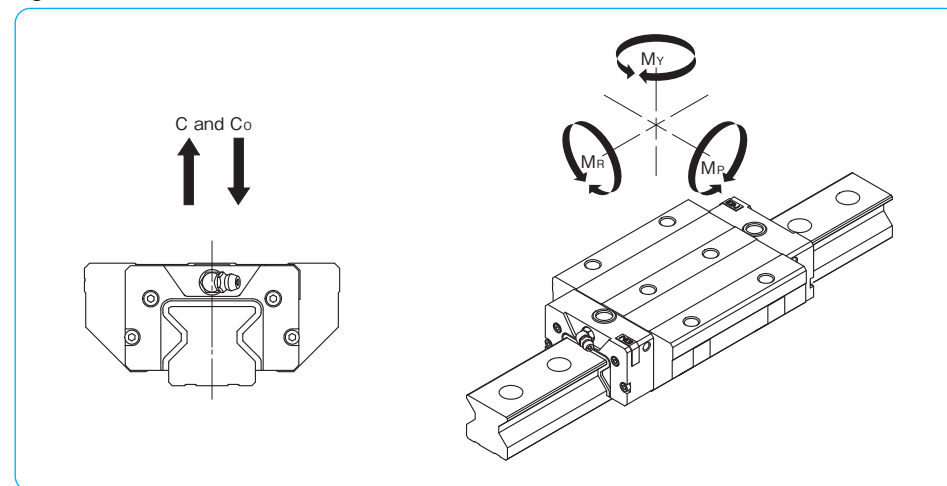

Rated Life Calculation

Needle rollers are used for the rolling elements in the EXRAIL guides, the life is calculated with the following equations;

If the stroke length and cycles are constant, life can be expressed in terms of time, the equation is;

$$L = \left(\frac{f_c \cdot f_T}{f_w} \cdot \frac{C_{100}}{P} \right)^{10/3} \cdot 100$$

$$L_h = \frac{L \cdot 10^6}{2 \cdot l_s \cdot n_1 \cdot 60}$$

L : rated life (km) f_c : contact coefficient
 f_T : temperature coefficient f_w : applied load coefficient
 C₁₀₀ : 100km basic dynamic load rating (N)
 P : applied load (N)
 ※ Refer to page Eng-5 for the coefficients.
 ※ The contact coefficient is applied when two or more blocks are used in close contact.

L_h : life time (hr) l_s : stroke length (mm)
 L : rated life (km) n₁ : number of cycles per minute (cpm)

RAIL LENGTH

NB offers a variety of commonly used rails as standard rail lengths (described in each dimension table). Other than the standard rail length can also be offered. In this case, if the N · (N) dimension is different from the value in each dimension table, please indicate as shown in the example. Please inquire us about changing the P dimension.

Please refer to the table values for the manufacturing range of N · (N) dimensions. Although the rail length can be offered out of the recommended range, please be careful not to interfere with the mounting hole or affect the assembly accuracy.

Example of part number structure (N · (N) comes after the the overall length)

X 35 HTF B 2 - 590 (N=15) H [N · (N) = 15]

X 55 YE B 2 - 880 (N=15/25) H [N=15, (N) = 25]

Table X-3 N Dimension unit : mm

part number	N	
	and over	less than
X35	10	30
X45	12.5	38.75
X55	15	45

Figure X-7 Rail

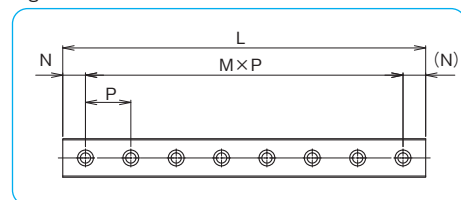

MOUNTING

Error Allowance of Mounting Surface

Since the EXRAIL guides have high rigidity, even the slightest error on the mounting surface greatly affects the service life and the dynamic frictional resistance. The values given in Table X-4 are the error allowance of the mounting surface.

Table X-4 Error Allowance of Mounting Surface unit : μm

allowance	X35	X45	X55
e1 error allowance in parallelism between 2 axes	5	7	8
e2 error allowance in vertical level between 2 axes	80 μm / 500mm rail span		

Figure X-8 Error Allowance in Parallelism between 2 Axes

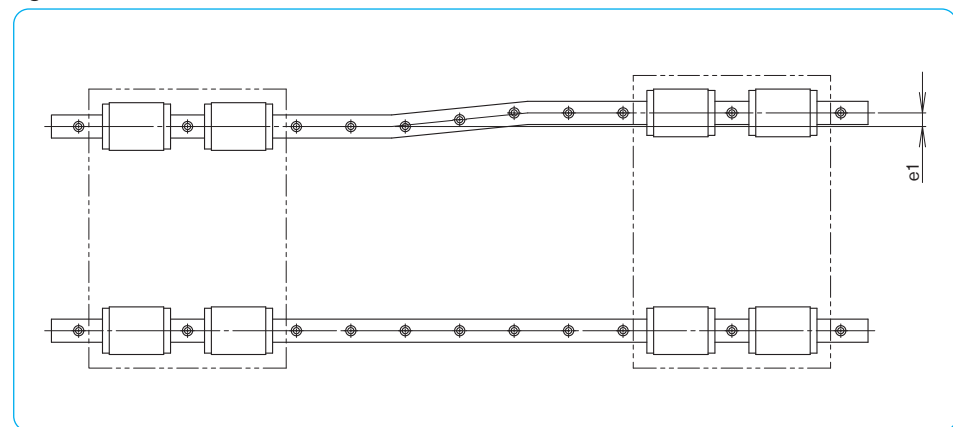
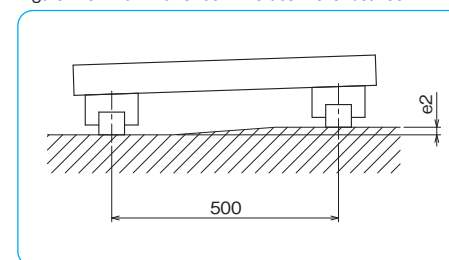

Figure X-9 Error Allowance in Vertical Level between 2 Axes



Mounting Surface Profile

The EXRAIL guides are generally mounted by pushing the reference surface of the rail and block against the shoulder of the mounting surface. The shoulder profile as shown in Figure X-10 should be provided in order to avoid interference with the corner of the rail or block. The recommended shoulder dimensions are shown in Table X-5.

Table X-5 Mounting Surface Profile unit : mm

part number	h ₁	h ₂	r _{1max}	r _{2max}
X35	7	4.5	1.5	1
X45	9	6.5	1.5	1.5
X55	10	7.5	2.5	1.5

Figure X-10 Mounting Surface Profile

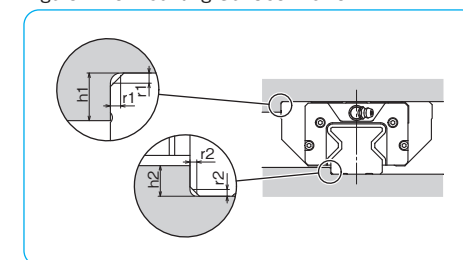

Fastening Torque for Rail

The screws to fasten the rail should be tightened to an equal torque using a torque wrench in order to secure the motion accuracy. The recommended torque values are given in Table X-6. Please adjust the torque depending on the operating conditions.

Table X-6 Recommended Torque unit : N · m

size	M8	M12	M14
recommended torque	27.6	96.4	154

(for steel alloy screws)

MOUNTING METHOD

Since the EXRAIL guides have high load ratings, they can be used in various types of machinery and other equipment in various configurations. Figure X-11 shows some typical EXRAIL guide arrangements.

Figure X-11 EXRAIL Guide Arrangements

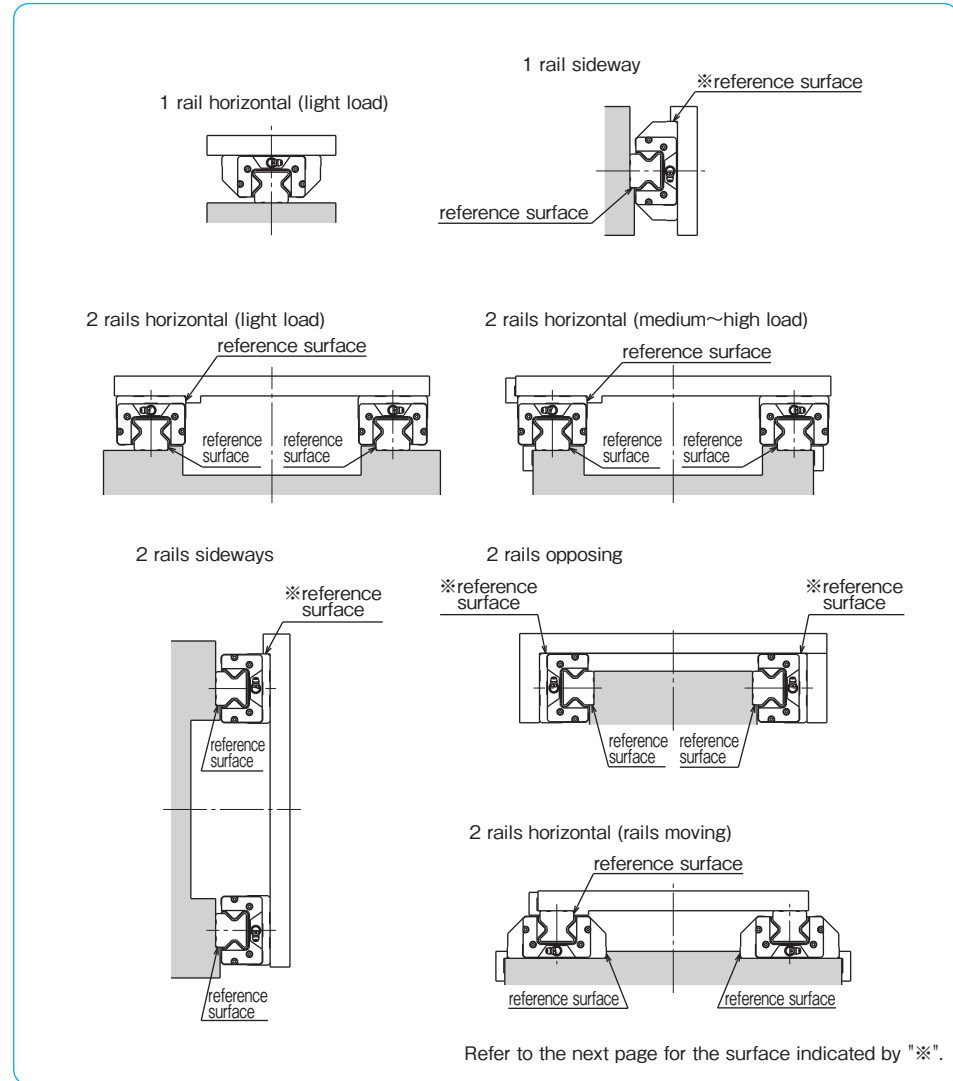

Mounting Surface and Accuracy

The EXRAIL guides are designed and manufactured to achieve high accuracy after mounting them to a machined mounting base. One typical way is to provide a shoulder on the mounting surface and align the reference surface of the rail or block against the shoulder (page X-7 Figure X10). To avoid corner interference, an undercut should be provided at the shoulder corner. Alternatively, the radius of the shoulder corner should be smaller than the radius of the slide guide block/rail corner.

The accuracy of the rail mounting surface affects the accuracy of the machinery or equipment along with the EXRAIL guide motion accuracy, therefore the accuracy of the mounting surface should be equivalent to the EXRAIL guide motion accuracy.

The specified preload may not be achievable due to deformation of the block if the mounted block surface is not flat (Figure X-12). Please pay close attention to achieve the specified flatness.

Note: Please contact NB for the rail straightness in case the mounting shoulder cannot be provided or the rigidity of the mounting surface is not enough.

Figure X-12 Effect of Flatness

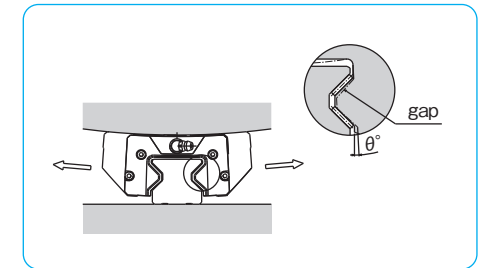

Reference Surface Indication

Reference surfaces are provided on EXRAIL to enable accurate and simplified mounting. They are located on the same side, as shown in Figure X-13, opposite to the NB mark.

Depending on the EXRAIL mounting arrangement, the standard reference surface may not ensure mounting accuracy (for example, 1 rail sideway or 2 rails opposing, page X-8 Figure X-11). In such cases, NB can provide a reference surface on the opposite side. Please specify the side when ordering.

Figure X-13 Reference Surface

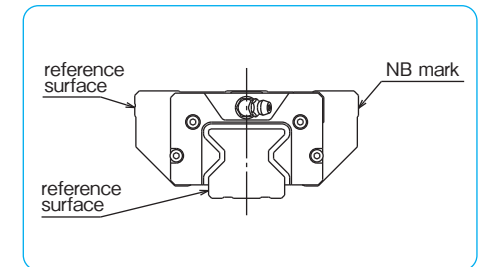

Mounting

In general, the EXRAIL guides are used with 2 rails in parallel. In that case, one rail is on the so-called reference side and the other is on the so-called adjustable side.

- Applications where shock/vibration and high load are involved/high accuracy is required. The effect of shock and vibration on accuracy is eliminated by using side pieces such as side plates (Figure X-14), tightening set screws (Figure X-15), or tapered gibs (Figure X-16).

Figure X-14 Using Side Plate

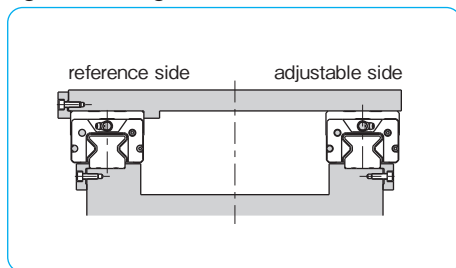

- Applications where light load and low speed are involved. Figures X-17~19 show the mounting methods when high accuracy is not required or the load capacity of the EXRAIL guide is sufficient due to a light load or low speed. In these cases, side pieces or reference surface may not be required.

Figure X-17 Without Side Piece

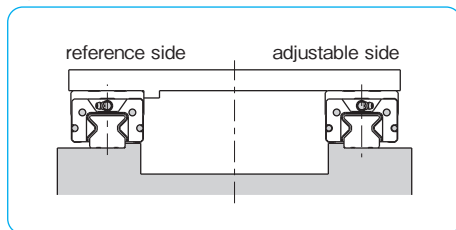

Figure X-15 Using Tightening Set Screw

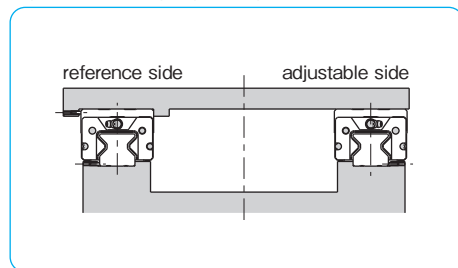

Figure X-16 Using Tapered Gib

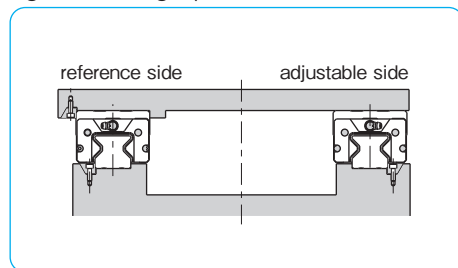

Figure X-18 No Reference Surface on Adjustable Side

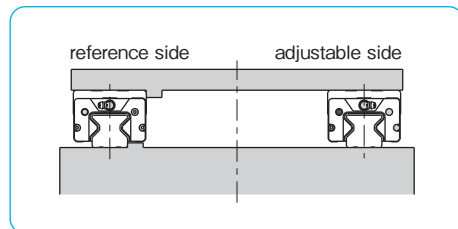
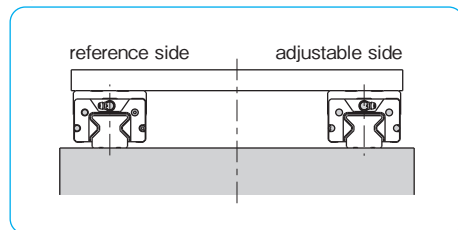

Figure X-19 Without Reference Surface



Mounting Procedure

When reference surfaces are provided for both the table and the base, please follow the following procedure to mount the EXRAIL guide.

1. Remove burrs, scratches, dust, etc. from the base and table. Apply a low viscosity oil to the base and the table. Place the EXRAIL guide on the base carefully. Temporarily tighten the rail mounting screws (Figure X-20a).
2. First, install the rail for reference side then tighten the screw for the side piece so that the installation reference surface and the rail reference surface are in close contact (Figure X-20b). If a side piece is not provided, use a C clamp (vise) to position the mounting reference surface and the rail reference surface so that they are in full contact with each other (Figure X-20c).
3. Tighten the mounting screws to the specified torque, and complete the mounting of the reference side rail. The rail is designed so that its accuracy is optimum when the screws are tightened to the specified torque value. Please refer to the recommended torque table for each product type (Figure X-20d).
4. Repeat steps 2 and 3 for mounting the rail on the adjustable side.
5. Move the blocks at the mounting location of the table, and place the table gently. Then slightly tighten the screws (Figure X-20e).
6. Fix the reference surface of the block against the table by the side piece. Tighten the mounting screws in a diagonal sequence (Figure X-20f).
7. In the same manner, tighten the mounting screws for the blocks on the adjustable side (Figure X-20g).
8. Finally, move the table through the entire stroke length to check if accelerate evenly. Please repeat 5 and 6 (2 to 6 when necessary) if acceleration is uneven. If acceleration is even, please do a final tightening of the screws.

Figure X-20 Mounting Procedure

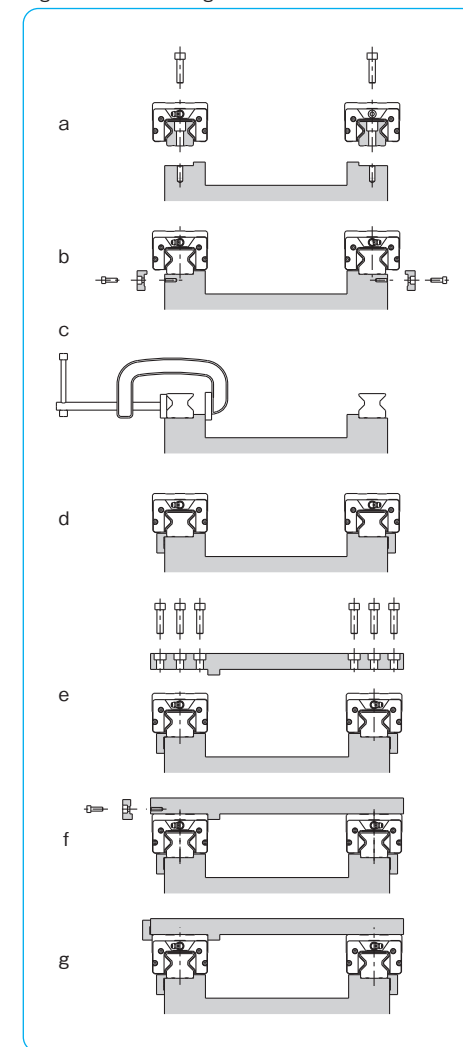

When the Reference Surface is Not Provided on the Adjustable Side

When a reference surface is not provided on the adjustable side, mount the 2 rails in parallel by using a jig, as mounted in Figure X-21. After mounting the reference-side EXRAIL guide, install the adjustable-side EXRAIL guide by moving the table to achieve parallelism.)

Figure X-21 Using a Jig

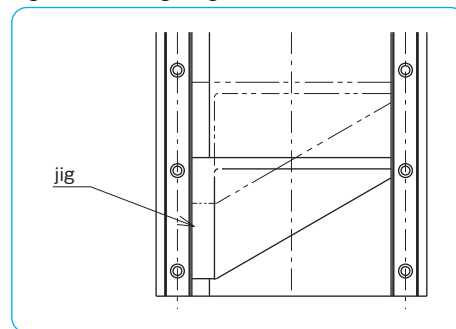

When the Reference Surface is Not Provided on the Reference Side

When a reference surface is not provided on the reference side, mount the 2 rails by using a reference surface close to the slide guide.

Temporarily fix the EXRAIL guide to the base, and mount an indicator on a measurement plate. Please fix the measurement plate on two or more blocks (Figure X-22).

Place the indicator against the reference surface of the base. Tighten the screws from one end of the rail to ensure straightness.

If there is no reference surface close-by to EXRAIL, use a straight edge to achieve straightness (Figure X-23).

Figure X-22 Using Base Reference Surface

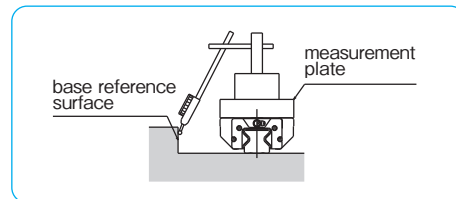
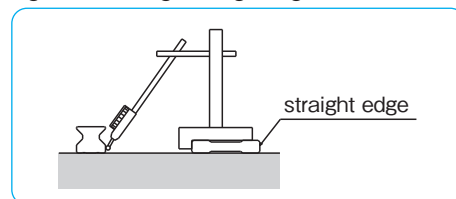

Figure X-23 Using a Straight Edge



DUST PREVENTION

Seals

Side-Seal

The side-seals prevent foreign particles and dust from entering the guide block in order to retain the motion accuracy, resulting in a long lifetime.

Under-Seal

The under-seals prevent foreign particles and dust entering from below depending on EXRAIL installation.

Inner-Seal

In harsh environments the inner-seals prevent foreign particles and dust from entering the guide block in order to retain the motion accuracy and rated product life.

Other seal options

It is possible to customize into double seals using double side seals, attaching scrapers for the purpose of removing large difficult to remove foreign substances such as welding spatter and chips, and also can combine double seals with scrapers. Please contact NB for details.

Figure X-24 Seals

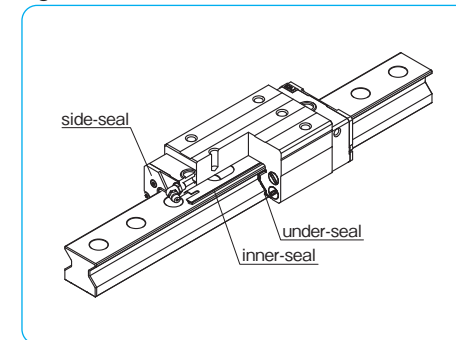

Rail Mounting Hole Caps

For EXRAIL guides, rail mounting hole caps as shown in Figure X-25 are available to prevent dust from entering the mounting holes. These caps are installed, after the rail is fixed to the base, by using a jig and slowly inserting them into the holes until their top surface is flush with the rail surface.

Table X-7 Rail Mounting Hole Caps

part number	dimensions			applicable EXRAIL
	size	D mm	t mm	
F8	M8	14	4	35
F12	M12	20	4.65	45
F14	M14	23	5.65	55

Figure X-25 Rail Mounting Hole Caps

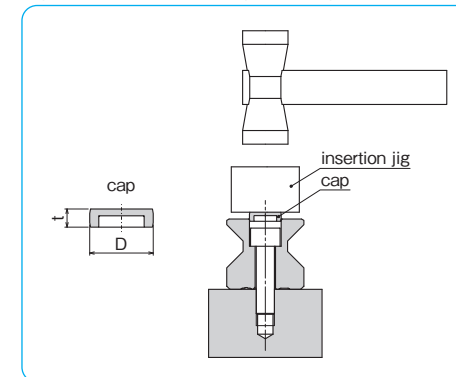

GREASE FITTING

A grease fitting is attached to the return cap of EXRAIL guide blocks for lubrication purposes. Unless otherwise specified, the orientation of the grease fitting is as shown in Figure X-26. When more than 4 blocks are used on one rail, the orientation of the grease fitting is same as the orientation shown in Figure X-26.

Figure X-26 Grease Fitting Orientation

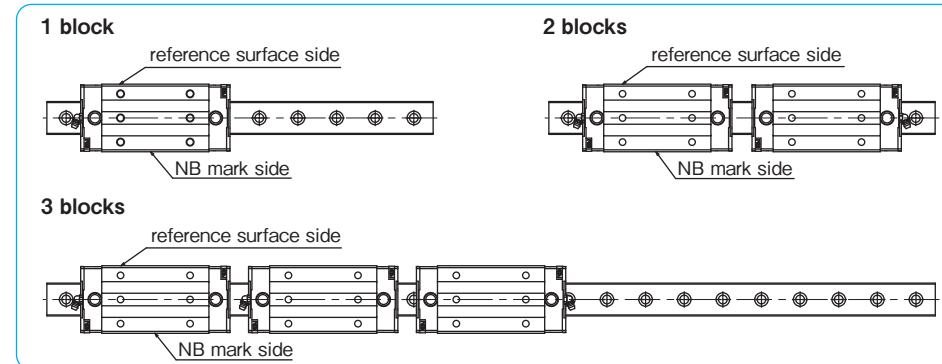

LUBRICATION

The standard installation of grease fitting for EXRAIL guides is at one front side of return cap. Grease fitting or pipe joint are also possible to be installed at side or top face of return cap (see Figure X-27). In such cases, machining oil hole or tapped hole will be machined at NB. For lubrication hole dimensions at side and top face, see Table X-8. When installing grease fitting or pipe joint at top face, O-ring and lubrication spacer is required (see Figure X-28). Please contact NB for details.

Figure X-27 Lubrication Spacer

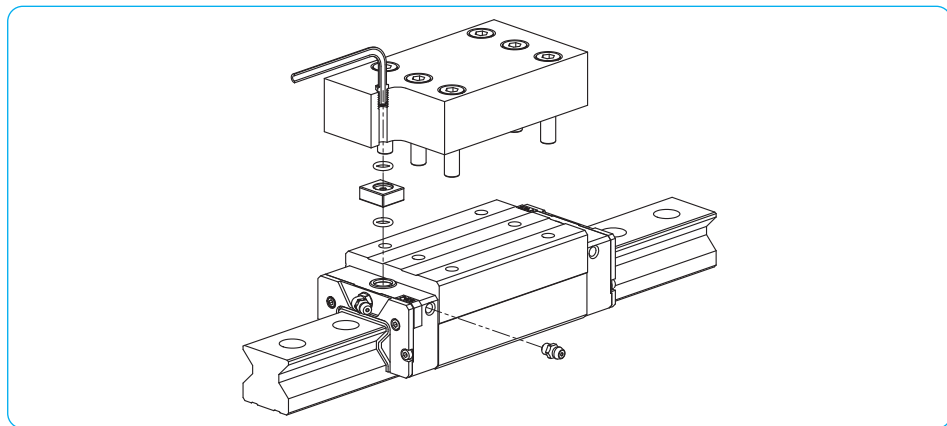

Figure X-28 Lubrication Hole

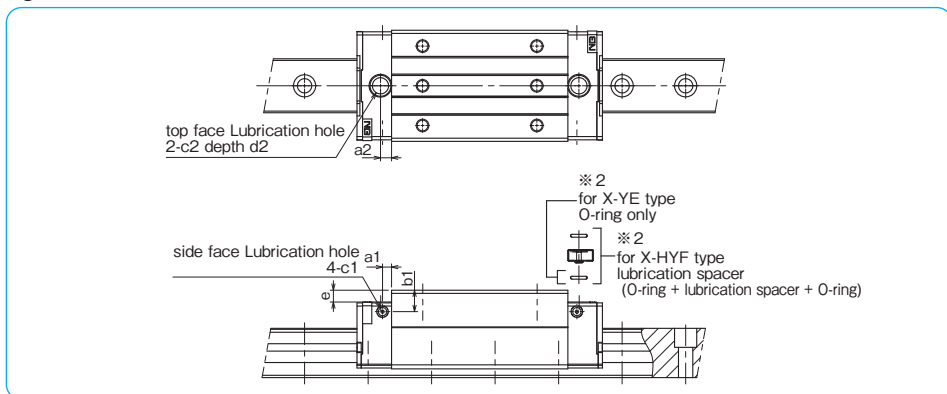

Table X-8 Lubrication Hole

unit : mm

part number	side face lubrication hole					top face lubrication hole					
	a1	b1	c1		grease fitting	c2	O-ring	d2	a2	e	
X-HYF	35	5.5	13.5	5.2	※1 for M6×0.75	M6F	10.2	P7	1.4	7	7.4
	45	7	18.1							8	10.4
	55	9	20.5							11	10.4
X-YE	35	5.5	6.5	5.2	※1 for M6×0.75	M6F	10.2	P7	1.4	7	0.4
	45	7	8.1							8	0.4
	55	9	10.5							11	0.4

※1 also installable for M6x1.0 grease fitting

※2 provided when top face lubrication hole is used

USE AND HANDLING PRECAUTIONS

EXRAIL guides are tuned precision components. Please pay special attention to the following notes.

- EXRAIL accuracy is adjusted based on specific block and rail set. It is NOT recommended to remove the block from the rail during installation.
- When block removal is necessary, please use a temporary (plastic dummy) rail to prevent the needle rollers from falling out.
- To remount a guide block on the rail, align the reference surface and the height between the rail and the R mark side of a temporary rail (see Figure X-29). The original combination of the block(s) and rail must be kept. The reference surface of both the block(s) and the rail must be aligned in the original condition.

Figure X-29 How to Remove Guide Block

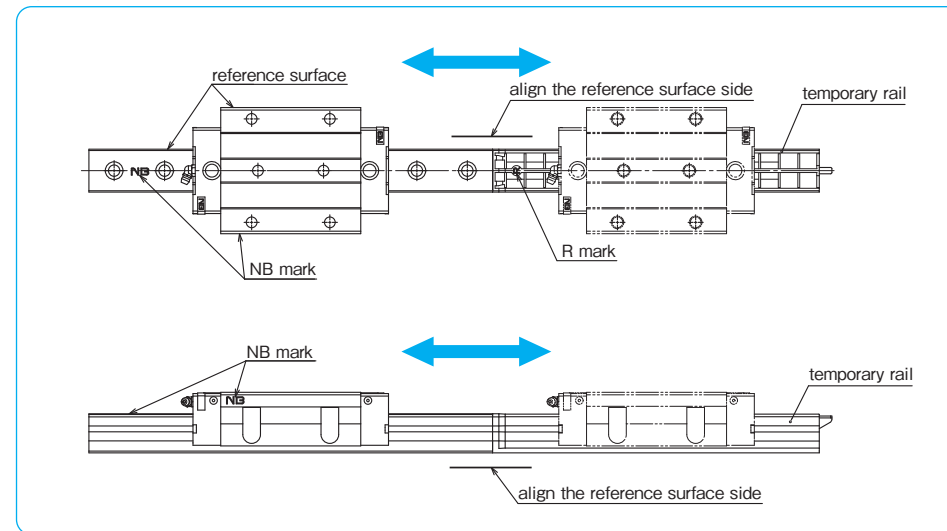

- Do not reverse the block on the rail to change the grease fitting orientation. Instead, relocate fitting to the opposite end by removing the plug, and re-insert the plug to the original location.
- Never disassemble the block. This will void warranty and support.
- Please remove burrs, dust, or any other debris from the base and table before installation.
- The EXRAIL guides are pre-lubricated for immediate use. Please re-lubricate with the same grade of grease as needed.

X-HYF TYPE

—Standard · Long Block Type—

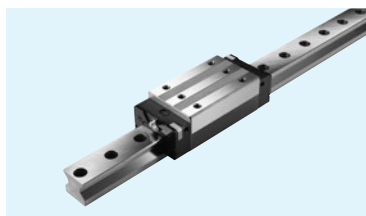

part number structure

example **X 35 HYF B 2 - 600 H / W2 F**

X	35	HYF	B	2	-	600	H	/	W2	F
X type	size	block style	seal (refer to page X-13) B : with side-seals + under-seals + inner-seals	number of blocks attached to one rail		total length of rail	accuracy grade (refer to page X-3) H : high			with rail mounting hole caps symbol for number of axes* blank: single axis W2 : 2 parallel axes W3 : 3 parallel axes

*The symbol for the number of axes does not mean the number of rails ordered.

part number	assembly dimensions		block dimensions										
	H mm	W mm	B mm	L ₁ mm	L ₂ mm	P ₁ mm	P ₂ mm	S ₁	f mm	T mm	b mm	E ₁ mm	T ₁ mm
X35HYF	55	18	70	155	111	50	72	M8	12	23.1	49	9.3	14.5
X45HYF	70	20.5	86	194	145	60	80	M10	17	30	62	13.6	19.9
X55HYF	80	23.5	100	238	181	75	95	M12	18	35	71	13.3	22

※1: basic dynamic load rating calculation based on rated life 100km

part number	standard rail length L mm																
X35	280	360	440	520	600	680	760	840	920	1,000	1,080	1,160	1,240	1,320	1,400	1,480	1,560
X45	570	675	780	885	990	1,095	1,200	1,305	1,410	1,515	1,620	1,725	1,830	1,935	2,040	2,145	2,250
X55	780	900	1,020	1,140	1,260	1,380	1,500	1,620	1,740	1,860	1,980	2,100	2,220	2,340	2,460	2,580	2,700

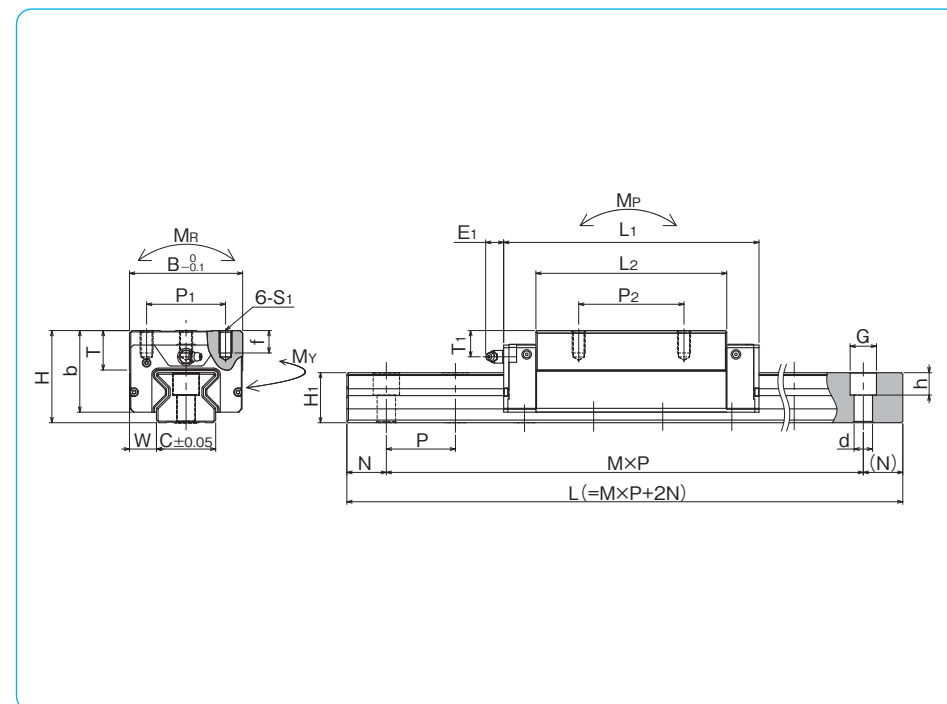

grease fitting	guide rail dimensions				basic load rating		allowable static moment			mass		block size	
	H ₁ mm	C mm	d×G×h mm	N mm	P mm	dynamic ^{※1} C ₁₀₀ kN	static C ₀ kN	M _P kN·m	M _Y kN·m	M _R kN·m	block kg		guide rail kg/m
B-M6F	31	34	9×14×12	20	40	49.2	204	3.73 21.0	3.73 21.0	4.11	2.1	6.3	35
B-R1/8	38	45	14×20×17	22.5	52.5	84.7	352	8.39 45.1	8.39 45.1	9.15	4.3	9.8	45
B-R1/8	43	53	16×23×20	30	60	130	542	15.9 84.4	15.9 84.4	16.3	7.1	13.3	55

M_{P2} and M_{R2} are allowable static moments when two blocks are used in close contact. 1kN≒102kgf 1N·m≒0.102kgf·m

														maximum length mm				
1,640	1,720	1,800	1,880	1,960	2,040	2,120	2,200	2,280	2,360	2,440	2,520	2,600	2,680	2,760	2,840	2,920	3,000	3,700
2,355	2,460	2,565	2,670	2,775	2,880	2,985												3,700
2,820	2,940	3,000																3,700

X-YE TYPE

—Flange • Long Block Type—

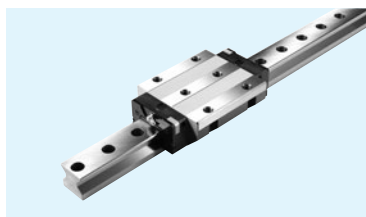

part number structure

example **X 35 YE B 2 - 600 H / W2 F**

X	35	YE	B	2	-	600	H	/	W2	F
X type	size	block style	seal (refer to page X-13) B: with side-seals + under-seals + inner-seals	number of blocks attached to one rail		total length of rail	accuracy grade (refer to page X-3) H: high		symbol for number of axes* blank: single axis W2: 2 parallel axes W3: 3 parallel axes	with rail mounting hole caps

※The symbol for the number of axes does not mean the number of rails ordered.

part number	assembly dimensions			block dimensions											
	H mm	W mm	B mm	L ₁ mm	L ₂ mm	P ₁ mm	P ₂ mm	S ₁	U mm	D mm	T mm	P ₃	S ₂	f mm	b mm
X35YE	48	33	100	155	111	82	62	M10	12	8.5	11.1	52	M10	7.5	42
X45YE	60	37.5	120	194	145	100	80	M12	15	10.5	14	60	M12	10	52
X55YE	70	43.5	140	238	181	116	95	M14	18	12.5	16	70	M14	13	61

※1: basic dynamic load rating calculation based on rated life 100km

part number	standard rail length L mm																
	280	360	440	520	600	680	760	840	920	1,000	1,080	1,160	1,240	1,320	1,400	1,480	1,560
X35	280	360	440	520	600	680	760	840	920	1,000	1,080	1,160	1,240	1,320	1,400	1,480	1,560
X45	570	675	780	885	990	1,095	1,200	1,305	1,410	1,515	1,620	1,725	1,830	1,935	2,040	2,145	2,250
X55	780	900	1,020	1,140	1,260	1,380	1,500	1,620	1,740	1,860	1,980	2,100	2,220	2,340	2,460	2,580	2,700

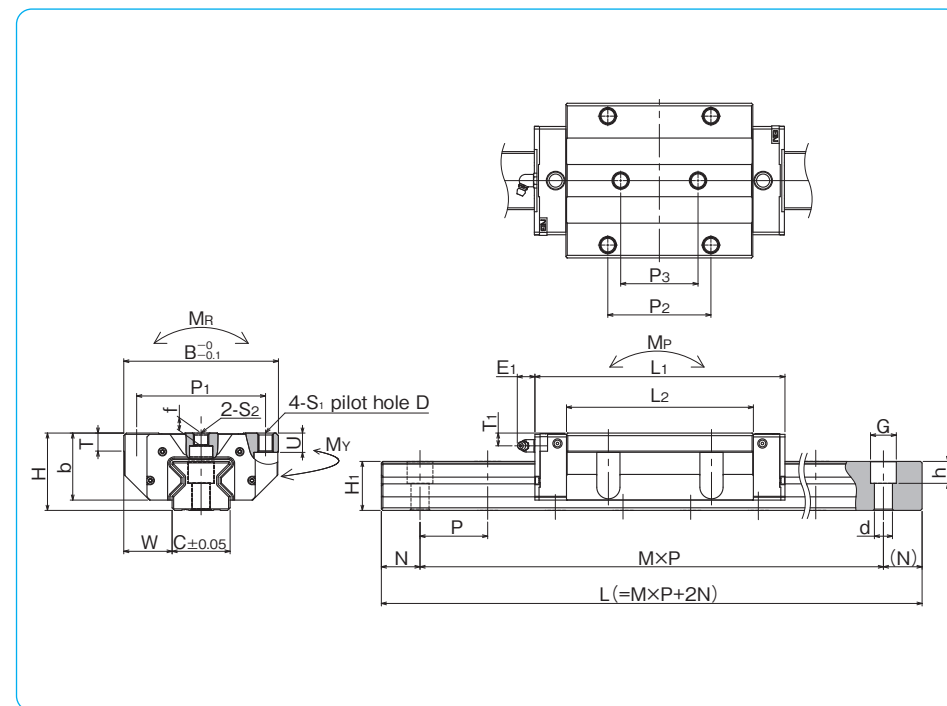

E ₁ mm	T ₁ mm	grease fitting	guide rail dimensions					basic load rating		allowable static moment			mass		block size
			H ₁ mm	C mm	d×G×h mm	N mm	P mm	dynamic ^{※1} C ₁₀₀ kN	static C ₀ kN	M _P kN·m	M _Y kN·m	M _R kN·m	block kg	guide rail kg/m	
9.3	7.5	B-M6F	31	34	9×14×12	20	40	49.2	204	3.73	3.73	4.11	2.4	6.3	35
13.6	9.9	B-R1/8	38	45	14×20×17	22.5	52.5	84.7	352	8.39	8.39	9.15	4.6	9.8	45
13.3	12	B-R1/8	43	53	16×23×20	30	60	130	542	15.9	15.9	16.3	8.0	13.3	55

M_{P2} and M_{Y2} are allowable static moments when two blocks are used in close contact. 1kN ≒ 102kgf 1N · m ≒ 0.102kgf · m

															maximum length mm			
1,640	1,720	1,800	1,880	1,960	2,040	2,120	2,200	2,280	2,360	2,440	2,520	2,600	2,680	2,760		2,840	2,920	3,000
2,355	2,460	2,565	2,670	2,775	2,880	2,985											3,700	
2,820	2,940	3,000														3,700		